

LIMITED WARRANTY

The Little Tikes Company makes fun, high quality toys. We warrant to the original purchaser that this product is free of defects in materials or workmanship for one year * from the date of purchase (dated sales receipt is required for proof of purchase). At the sole election of The Little Tikes Company, the only remedies available under this warranty will be the replacement of the defective part or replacement of the product. This warranty is valid only if the product has been assembled and maintained per the instructions. This warranty does not cover abuse, accident, cosmetic issues such as fading or scratches from normal wear, or any other cause not arising from defects in material and workmanship. *The warranty period is three (3) months for daycare or commercial purchasers.

U.S.A and Canada: For warranty service or replacement part information, please visit our website at www.littletikes.com, call 1-800-321-0183 or write to: Consumer Service, The Little Tikes Company, 2180 Barlow Road, Hudson OH 44236, U.S.A. Some replacement parts may be available for purchase after warranty expires—contact us for details.

Outside U.S.A and Canada: Contact place of purchase for warranty service. This warranty gives you specific legal rights, and you may also have other rights, which vary from country/state to country/state. Some countries/states do not allow the exclusion or limitation of incidental or consequential damages, so the above limitation or exclusion may not apply to you.



SKU: 659324C3

AGES 1-3 YEARS
ADULT ASSEMBLY AND SUPERVISION REQUIRED

CONTENTS

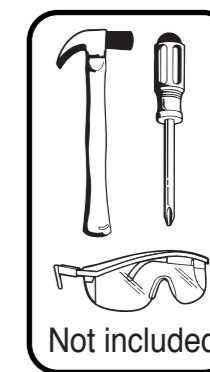
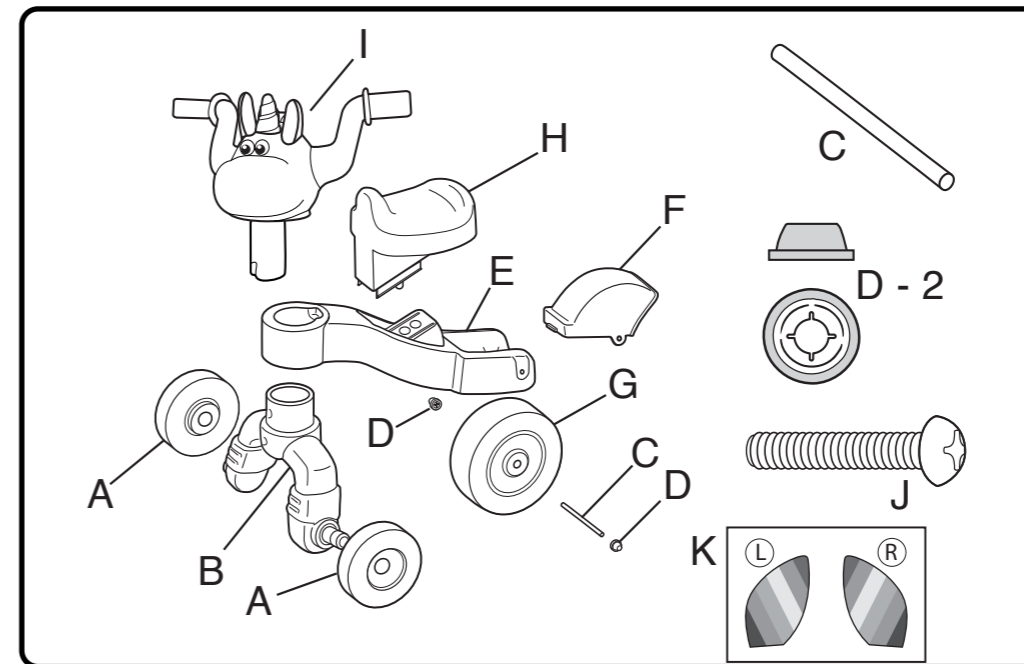

Illustrations are for reference only. Styles may vary from actual contents.
Please remove all packaging including tags, ties & tacking stitches before giving this product to a child.

Please keep this manual as it contains important information.



© The Little Tikes Company, an MGA Entertainment company. LITTLE TIKES® is a trademark of Little Tikes in the U.S. and other countries. All logos, names, characters, likenesses, images, slogans, and packaging appearance are the property of Little Tikes.

Printed in China • 0521-0-C3



www.littletikes.com
www.littletikes.co.uk
www.littletikes.com.au

Little Tikes Consumer Service
2180 Barlow Road
Hudson, Ohio 44236 U.S.A.
1-800-321-0183

MGA Entertainment UK Ltd.
50 Presley Way, Crownhill, Milton
Keynes, MK8 0ES, Bucks, UK
support@LittleTikesStore.co.uk
Tel: +0 800 521 558

MGA Entertainment (Netherlands) B.V.
Baronie 68-70, 2404 XG Alphen a/d Rijn,
The Netherlands
Tel: +31 (0) 172 758038

Imported by MGA Entertainment Australia Pty Ltd
Suite 2.02, 32 Delhi Road
Macquarie Park NSW 2113
1300 059 676

⚠ WARNING

ADULT ASSEMBLY REQUIRED.

- Keep these instructions for future reference.
- Prior to assembly, this package contains small parts: hardware which is a choking hazard and may contain sharp edges and sharp points. Keep away from children until assembled.
- Protect your eyes. Always wear safety glasses when using a hammer.
- Adult supervision required. Do not leave children unattended.
- DO NOT allow child to climb on the unit.
- Ride-on toys should not be used near swimming pools, on or near steps, hills, roadways, or inclines.
- Ride-on toy should be used with caution since skill is required to avoid falls or collisions causing injury to the child or third parties.
- Shoes must be worn at all times.
- Only one rider at a time.
- Maximum weight: 50 lbs. (23 kg) per child.
- Not to be used by children over 36 months due to size limitations.

CARE INSTRUCTIONS

- To prolong product life, do not leave the unit outside during inclement weather.
- Check all screws, capnuts and hardware twice monthly during usage and tighten as needed. Replace when necessary.

ASSEMBLY

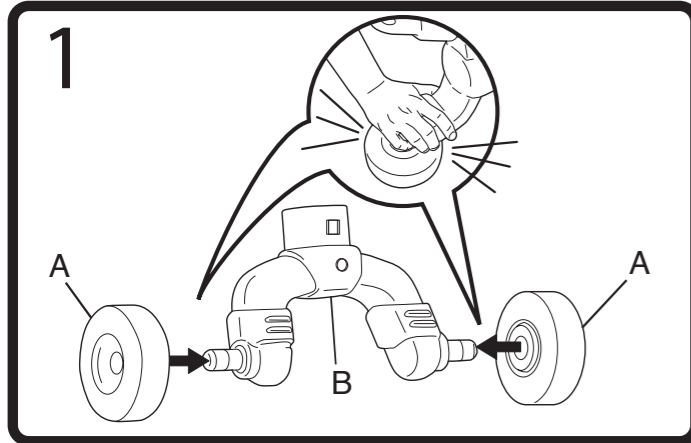

1 Place a front wheel (A) onto the peg on the front wheel assembly (B), making sure the word "inward" on the wheel faces toward the center of the unit. Press firmly until the wheel snaps in place. Repeat for the other wheel.

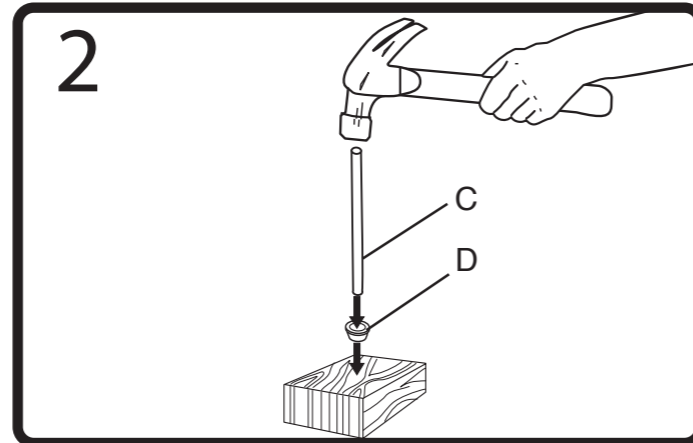

2 Place one axle cap (D), color side down, onto a piece of scrap wood (not included). Using a hammer, tap the axle (C) firmly onto the axle cap. Then, set it aside. **Always wear safety glasses when using a hammer.**

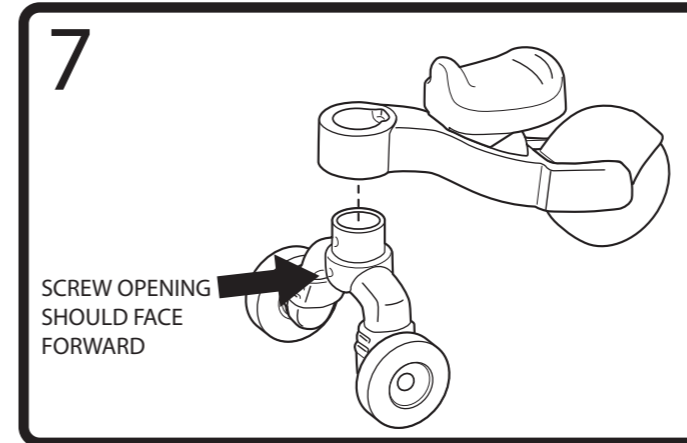

7 Place the front opening in the center unit over the top of the front wheel assembly, making sure the screw opening in the assembly is facing forward. Then, press down firmly.

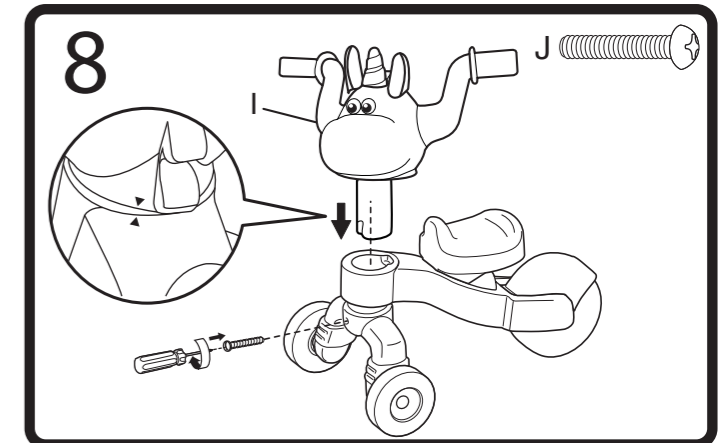

8 Place the neck of the handlebars into the opening in the center unit and align the arrows. Then, press down until it snaps into place. Using a Philip screwdriver (not included) install the screw (J) in the opening on the front of the wheel assembly.

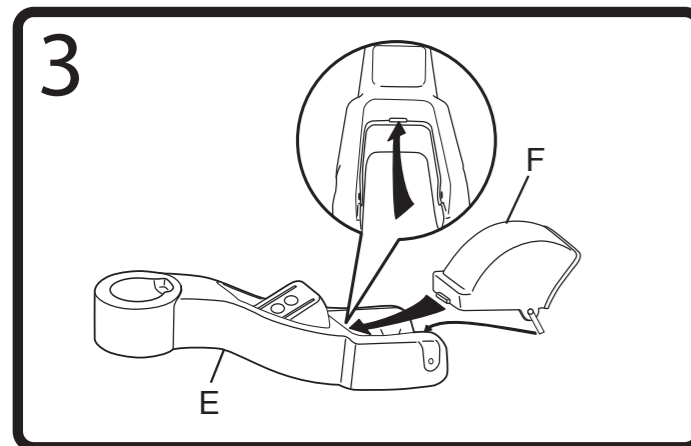

3 Place the pegs on the fender (F) into the slots on the fork of the center unit (E) and press them into place. Then, press down on the front edge of the fender until the lip of the fender snaps into the slot in the center unit.

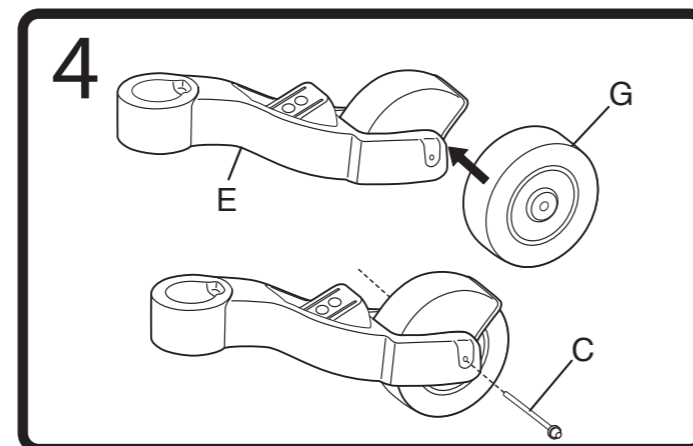

4 Place the back wheel (G) into the fork of the center unit (E). Slide the axle (C) through opening on the fender, wheel, fork assembly and out the other side.

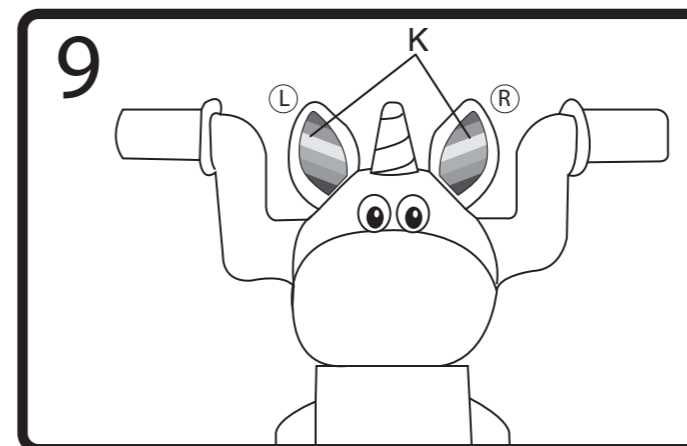

9 Attach the decal stickers to the unicorn's ears, making sure to attach the L to the left ear and the R to the right ear. NOTE: Decals must be applied to a clean, dry surface. Wipe clean with a dry rag before application. Remove air from under the decals by applying pressure to the decals starting from the center, and work towards the edges.

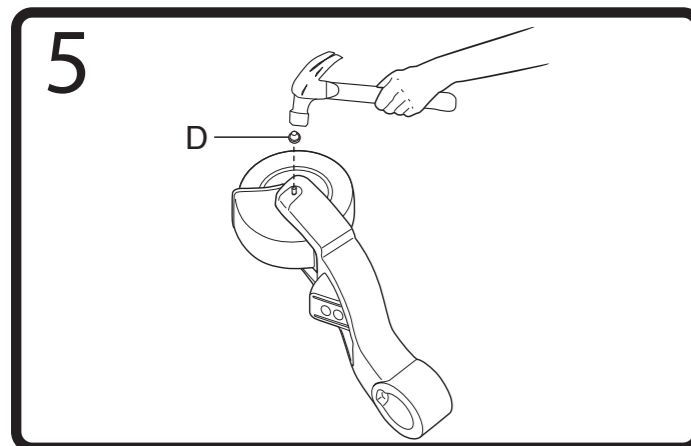

5 Lay the unit on its side and, using a hammer, tap the second axle cap (D) onto the other end of the axle.

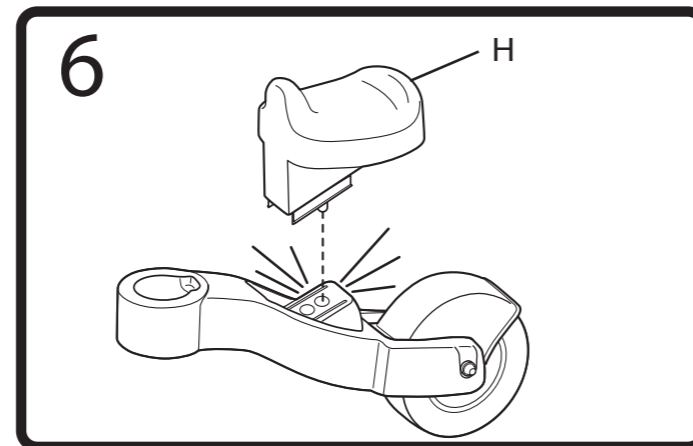

6 Place the seat onto the center unit, making sure the peg on the underside of the seat fits in the opening closest to the front of the rider. Press firmly until the seat snaps in place.

NOTE: To adjust the seat as the child grows, press upward on the spring-loaded peg on the underside of the seat and slide the seat back until the peg slips into the second opening in the center unit.



When using the hammer, it is important to **tap the axle cap**. If the cap is placed too tightly, the wheel will not spin.