

Slam 'N Slide Water Park

Instructions for Installation and Operation

Ages: 5 - 10 years

CAUTION: ELECTRICALLY OPERATED PRODUCT.

NOT RECOMMENDED FOR CHILDREN UNDER 5 YEARS OF AGE. AS WITH ALL ELECTRIC PRODUCTS, PRECAUTIONS SHOULD BE OBSERVED DURING USE AND HANDLING TO PREVENT ELECTRIC SHOCK.

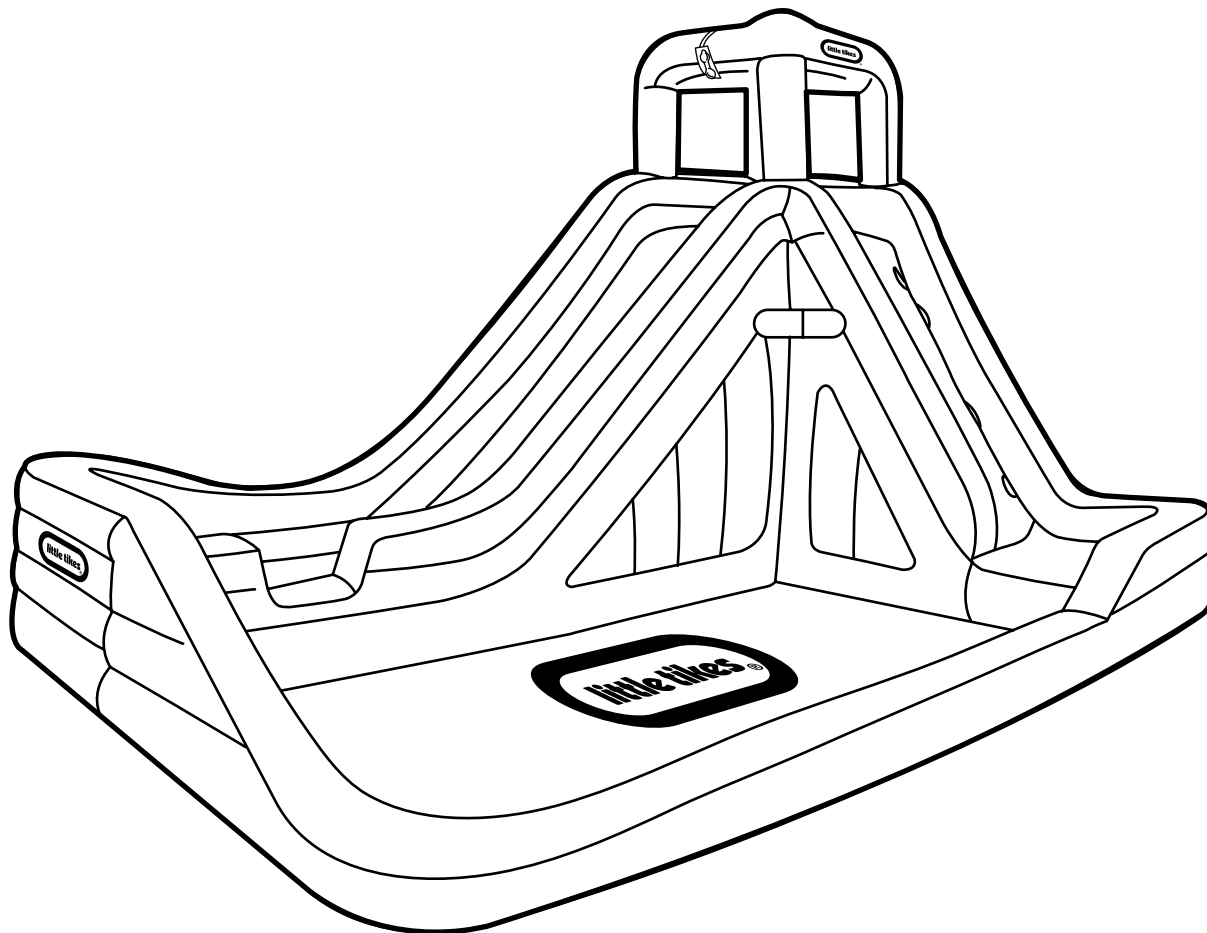

ATTENTION:

IF YOU ENCOUNTER PROBLEMS, OR HAVE QUESTIONS,
PLEASE DO NOT RETURN THE SLAM 'N SLIDE WATER PARK TO THE PLACE OF PURCHASE.
PLEASE CALL OUR QUALIFIED CUSTOMER SERVICE TECHNICIANS AT 1-800-321-0183

IMPORTANT SAFETY RULES

READ, UNDERSTAND, FOLLOW CAREFULLY AND RETAIN ALL INSTRUCTIONS
BEFORE INSTALLING AND USING THIS PRODUCT.



607837

INTRODUCTION

This huge inflatable water slide and play area measures 9W x 12D x 14.5H feet! With its tall, strong, inflatable walls, fun slides, play area and pool, the Slam 'N Slide Water Park provides tons of water fun, while the heavy duty blower maintains a continuous air flow! It's the perfect water play area for the Little Tikes™ in your life!

CONTENTS

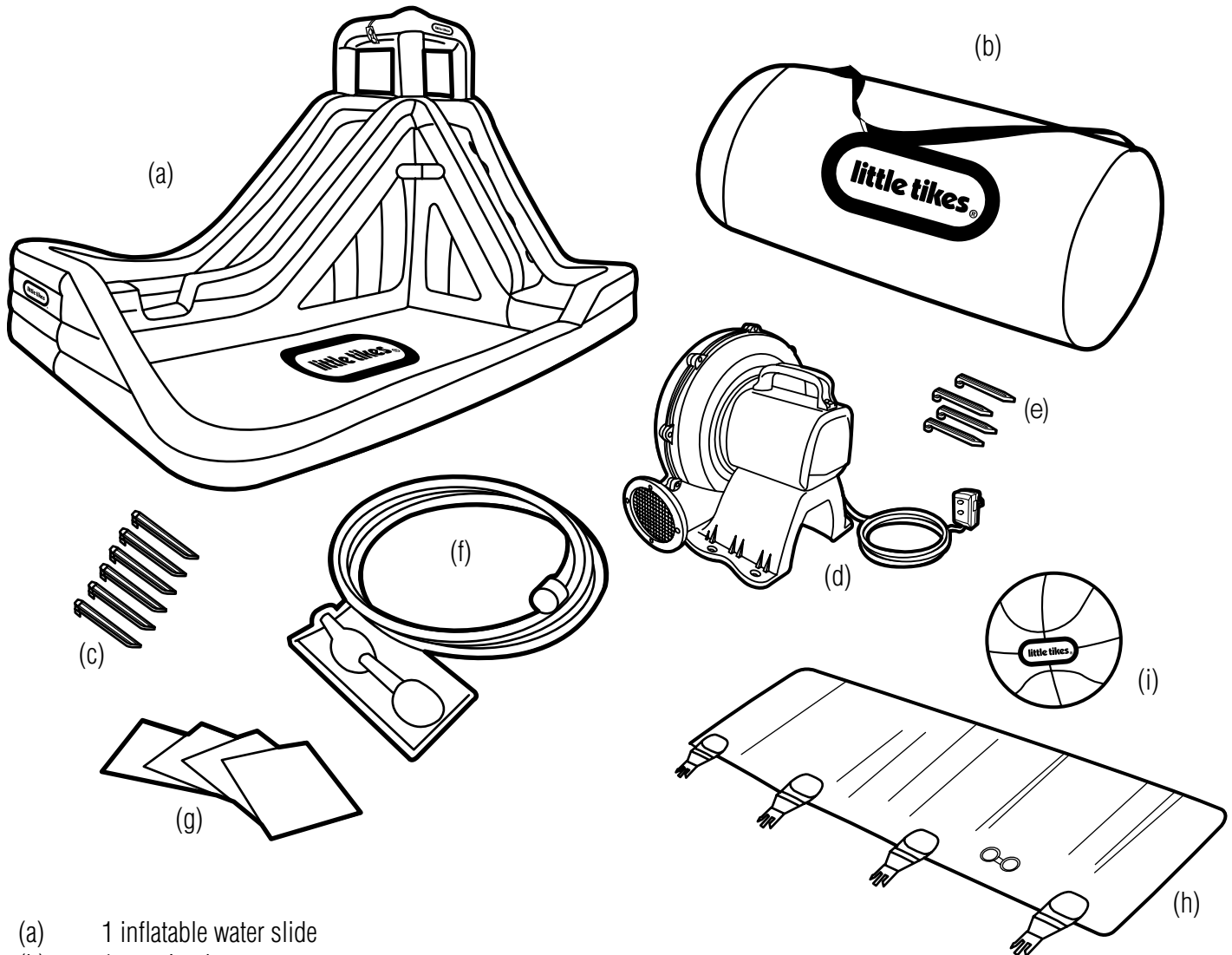

- (a) 1 inflatable water slide
- (b) 1 carrying bag
- (c) 6 water slide stakes
- (d) 1 blower with plug
- (e) 4 blower stakes
- (f) 1 complete hose assembly including:
 - 1 faucet connector section
 - 1 double outlet sprinkler heads for slides and ball
- (g) 4 repair patches
- (h) 1 water anchor bag
- (i) 1 inflatable basketball



SAFETY WARNINGS: ELECTRICAL BLOWER



**LISTED
E230679**

DO NOT IMMERSE IN WATER OR USE NEAR OR IN CONTACT WITH WATER.

**BLOWER SPECIFICATIONS: MODEL: W-2L
ELECTRICAL RATING: 115V AC, 60HZ, 3.8A,
437W**

Specifications may change without notice.

FAILURE TO FOLLOW THESE INSTRUCTIONS

**COULD
RESULT IN SERIOUS INJURY OR DEATH.**

⚠ CAUTION: The blower is a high volume blower, and is capable of moving large volumes of air very quickly. Place the blower in an area where it will not draw in dirt or leaves. Keep the blower and power cord away from children, pets, bodies of water, pools, spas, and traffic.

INSTRUCTIONS FOR BLOWER INSTALLATION AND OPERATION

NOTE: Set up as close to the power source as possible. The product should be periodically examined for potentially unsafe conditions such as: damaged cord, plug, housing or parts, and in the event such damage is found, the product should not be used until properly repaired. Never leave the blower outside in the rain or exposed to the elements when not in use. When in use, do not place the cord across traffic areas, water or damp areas. The blower should be placed on a stable surface and anchored per product instructions. The power cord of the blower is equipped with a Ground Fault Current Interrupter (GFCI) plug.

- 1) Make sure that power switch of the blower is in the "OFF" position. Plug the blower into a properly grounded outlet.
- 2) If the GFCI has been tripped, press the "RESET" button to restore power to the blower.
- 3) Set the power switch of the blower to "ON" to inflate. After use, turn the power to "OFF".
- 4) To disconnect the plug, have an adult grip it tightly and pull it from the wall outlet.

⚠ WARNING:

- Adult installation and supervision required.
- This blower is for residential use only. It is not intended to be used in commercial or industrial settings.
- Never insert fingers, pencils or any other object through the grill at ANY time.
- Do not operate blower with a damaged cord or plug.
- Do not operate in the presence of explosive and/or flammable fumes.
- Never connect the blower to any solid – state speed control device.
- Do not use extension cords.
- Always unplug the blower before servicing.

INSTRUCTIONS FOR BLOWER CLEANING AND STORAGE

Do not immerse the blower in water. Unplug the blower before cleaning. To clean: wipe with a damp cloth. The blower does not require any lubrication and has no user serviceable parts. Do not attempt to service the blower. When not in use, store the blower indoors in a dry place. Store the blower upright on a stable surface. Loosely coil the cord and place it beside the blower.

GROUNDING METHODS

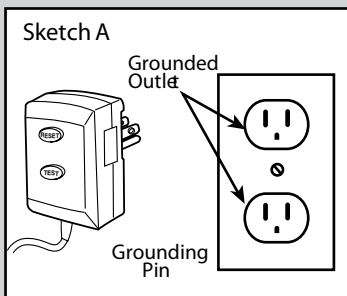

USE ONLY ON GROUNDED OUTLETS



GROUNDING INSTRUCTIONS FOR ALL GROUNDED, CORD-CONNECTED PRODUCTS

This product is for use on a nominal 120 Volt, 15 Ampere supply circuit, with grounded outlets (sketch A) wired in accordance with all local electrical codes and ordinances. Make sure that the circuit is not overloaded while the blower is in operation. If the outlet is dissimilar to the one illustrated in the sketch, do not try to use temporary adapters, or modify the plug. Do not use the product until a properly grounded outlet is installed by a qualified electrician.



SAFETY WARNINGS: SETUP

ADULT SETUP REQUIRED. Falls on hard surfaces could result in head or other serious injuries. Never install on concrete, asphalt, packed earth or other hard surfaces.

- Intended for outdoor domestic family use only. Not for use in public areas or as a rental.
- Product is heavy. Use caution when lifting.
- Product should never be dragged across concrete, pavement or other rough surfaces.
- Keep fabric away from flame or heat sources.
- Do not set up in windy or rainy conditions: sudden gusts of wind may lift the product off of the ground.
- Product can be installed in any orientation in relation to the sun, since there are no metal components or surfaces that can absorb excessive solar radiation.
- Set-up in outdoor location only that meets the following criteria:
 - Place on level ground on grass or earth to allow proper use of stakes. Placing on slanted or uneven surfaces may cause product to tip.
 - Stakes should be placed at an angle for better anchorage, and should be driven under the ground to prevent tripping.
 - Minimum clearance zones: place at least 6.6 ft (2m) away from any other interfering objects, such as fences, buildings, trees, overhead branches, laundry lines, electrical wires, or open bodies of water or sources of water.
- Make sure that area around the product is secure by adding safety barriers, if necessary, to keep young children and pets from gaining access.
- Install all attachments and ballasts supplied with this product.
- Do not use extension cords with the blower. Set-up as close to the power source as possible. Blower must be securely anchored to the ground before use.
- CAUTION: the blower is capable of moving large volumes of air very quickly. Place the blower on an area where it will not draw dirt or leaves. Keep blower and power cord away from children, water and traffic.
- ATTENTION: Blower must remain ON and continuously inflate during use. Air flow through seams is normal. Do not try to seal or repair seams. Product should be fully inflated before children are allowed to play.



SAFETY WARNINGS: USAGE

ADULT SUPERVISION REQUIRED. NEVER LEAVE CHILDREN UNATTENDED.



Total weight on inflated surface: 300 lbs. (136 kg.)



Adult supervision required. Do not leave children unattended.



Age 5-10 years



No sharp objects.



No shoes, no glasses.

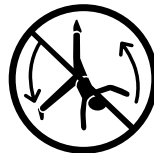

No flipping.



Do not slide head first.



No wrestling.



No hands or feet



Do not use in windy conditions.



Do not leave out in rain.



Do not allow children to touch fan or electrical cord.

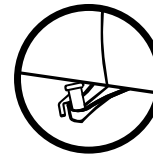

Must be anchored using stakes.

- Constant, competent adult supervision of children and other young users is required at all times.
- Keep the area around the product clean, and clear of objects, to prevent slips and falls.
- Instruct children on the proper use of this product:
 - Children should not wear loose or baggy clothing, scarves, hoods or clothing with drawstrings.
 - Children must remove helmets, headgear, shoes and glasses, as well as any sharp objects from their pockets, as they may puncture the bouncing surfaces.
 - Children should never be allowed to bring toys or other objects, while playing with the inflatable.
 - Children should never attach items, such as jump ropes, clothesline, pet leashes, cables and chains, as they may cause a strangulation hazard.
 - Keep pets away from product.
 - Children should bounce away from others, and stay away from openings and side walls.
 - Children must not jump onto or off the product.
 - Do not let children play together who are unevenly matched in weight and height.
 - Only one child at a time is allowed on each climber and slide.
- Children must not slide down head first or on their stomach
- Do not let children walk on the side where blower motor is attached.
- Always dry product before storage.
- Never use product as a flotation or life saving device.
- Always check the product and all its anchorage points during use, and re-secure, as appropriate. Always check for excessive air loss, and re-inflate before allowing play to continue.
- As an outdoor product, this inflatable is subject to wear and deterioration. Keep product properly maintained and watch for signs of fabric failure. Weak or torn surfaces must be repaired promptly.
- If product contains a pool:
 - Never dive or jump into the pool area.
 - Do not sit on the edges of the pool as flooding may occur.
 - Always drain product after use. Do not leave it inflated or full of water overnight.
 - Keep the pool area clean to prevent illness. Instruct all children never to drink pool water and to practice good hygiene.

Water Park Placement

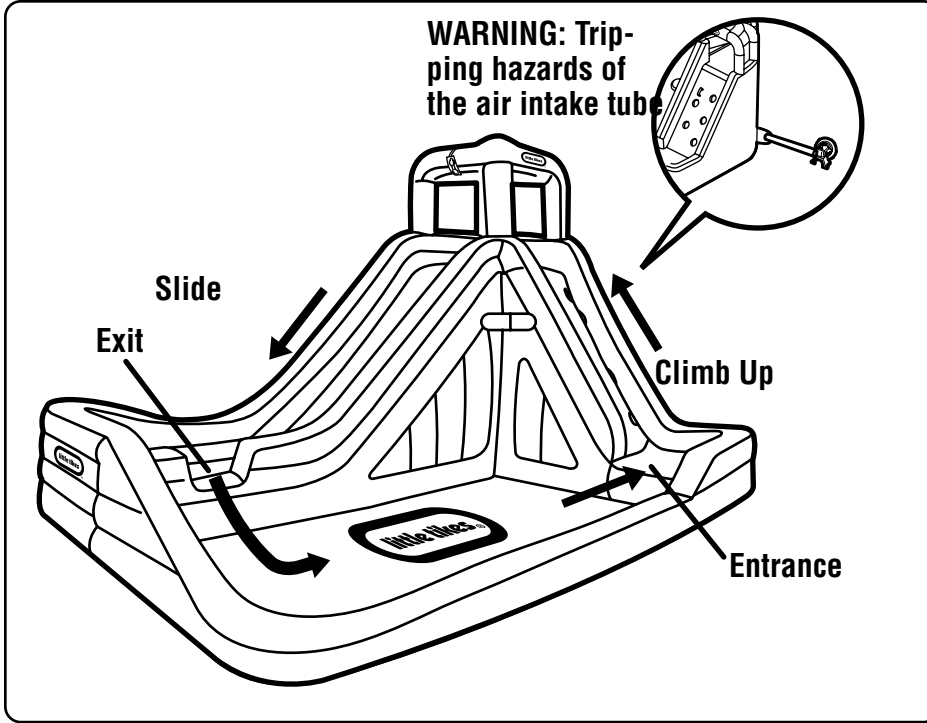

Designate a flat, level, grassy surface that allows for 6.6 feet (2m) of minimum clearance around the Water Park. **NOTE:** DO NOT place the Water Slide on a hard surface like asphalt, concrete or packed earth as both serious bodily injury and damage to the Water Park could result.

ASSEMBLY AREAS

- Make sure the assembly area is flat and level and is free of rocks, sharp objects, or other obstructions.
- Do Not set up the Water Park on a slope or incline.
- Do Not set up the Water Park on hard-packed earth, asphalt, decking or any hard surface as doing so may result in physical injury and/or damage to the Water Park.
- Once the Water Park is inflated or filled with water, do not attempt to drag it to another location.
- Check your local county or city regulations for requirements on securing the pool.
- Secure the pool from unauthorized use.

Minimum Clearance Zones

MINIMUM CLEARANCE ZONES: Make sure that there is a 6.6-foot (2m) obstacle-free zone around the Water Park and overhead. See Fig. 1 and 1a below:

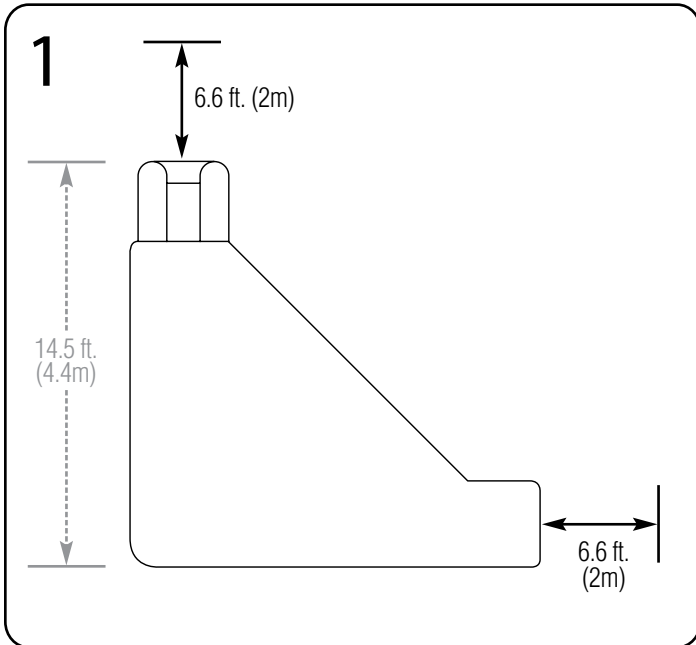

INFLATABLE SIZE: 9 x 12 x 14.5 feet

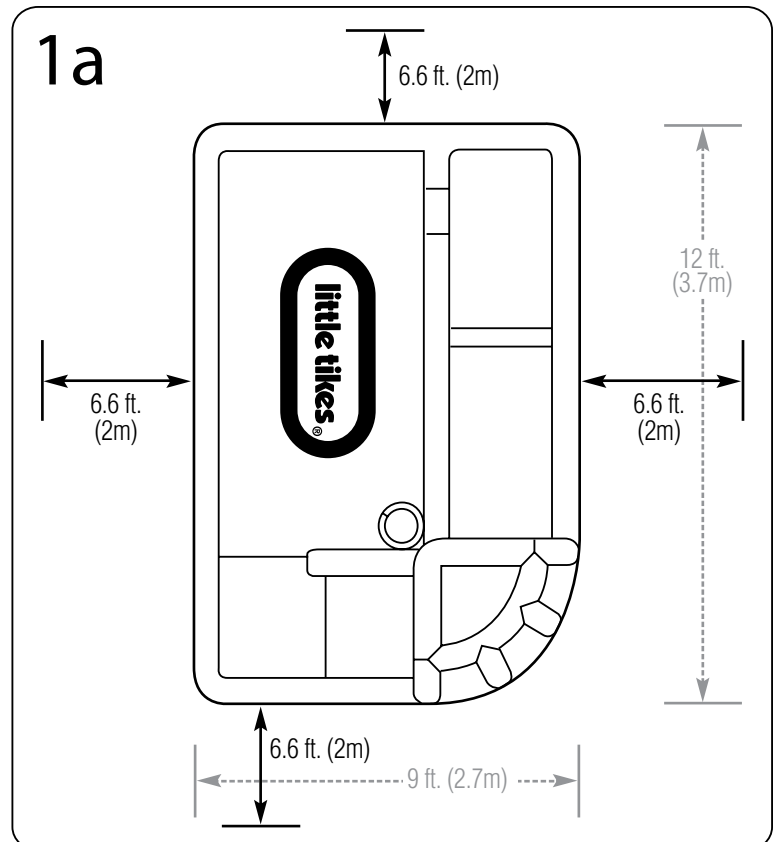

Unfolding Water Park

2

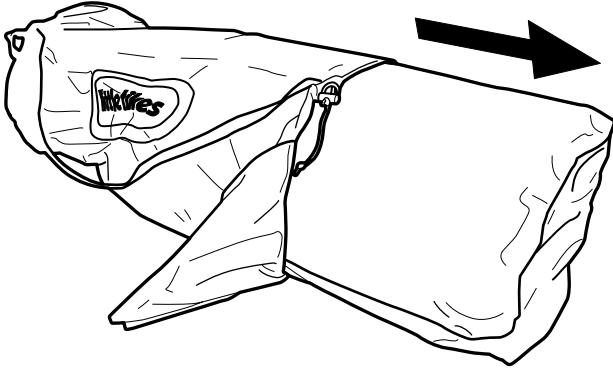

Remove contents from the carrying bag.

3

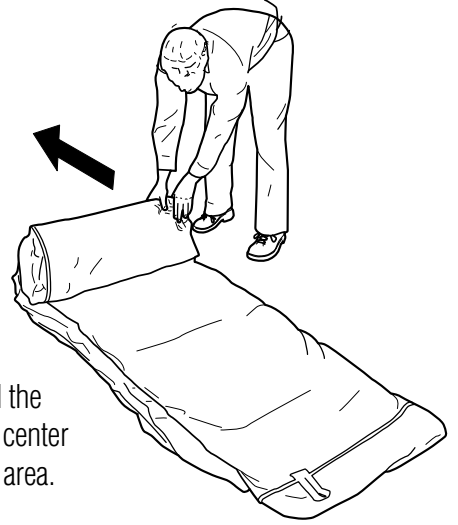

Unroll and unfold the Water Park in the center of the designated area.

4

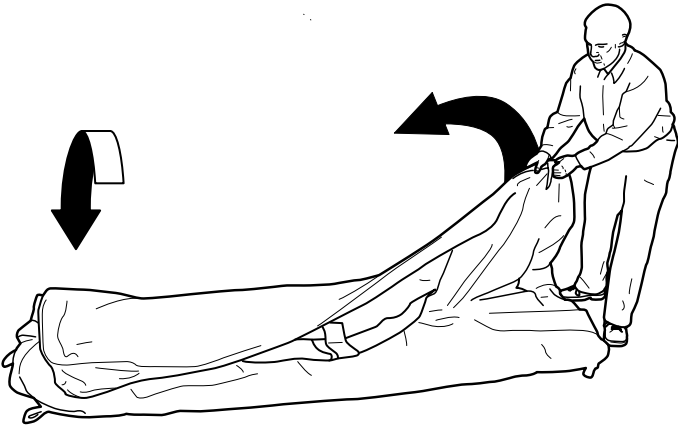

5



6

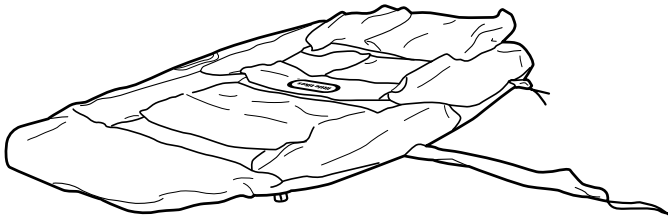

Blower Setup

1

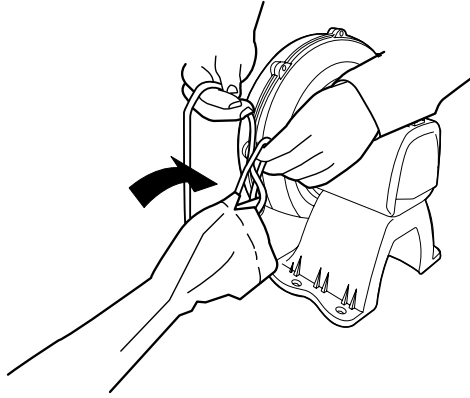

Attach the long Air Intake Tube on the Water Park to the mouth of the Blower Motor with the attached drawstring. Make sure the Intake Tube is free of twists or kinks.

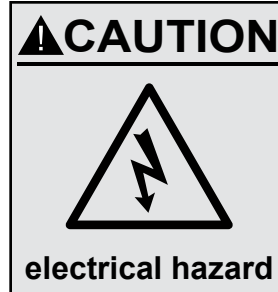

CAUTION: Heed all signs and warning labels on the blower motor.

NOTE: Position the blower motor perpendicular and level to the Water Park. Make sure that the blower is upright on a stable surface. Do not place the blower in an area where it can suck up dirt, leaves and other debris. Make sure that the blower is at least 6.6 feet (2m) away from any structure or obstacle such as a fence, garage, overhanging branches or electrical wires.

2

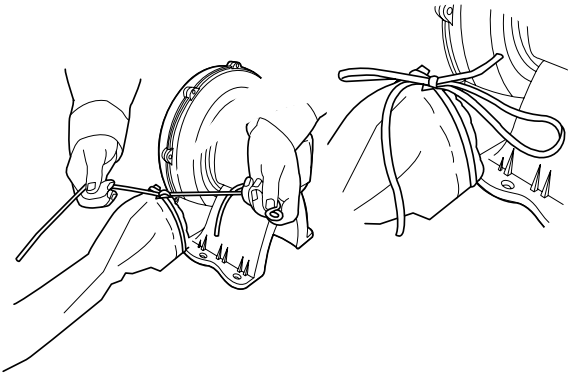

Wrap the drawstring once around the Intake Tube before tying off. This ensures a tight seal.

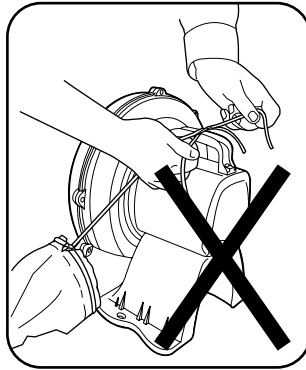

3

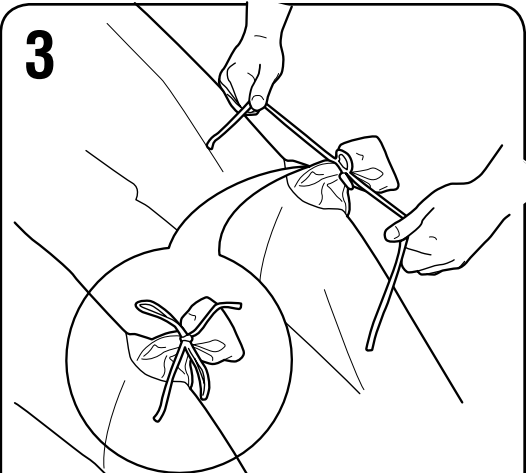

Tie off the short Air Outlet Tube tightly to make a good seal.

⚠ BLOWER CAUTIONS:

- Do not open or try to service the blower. If blower needs servicing, take it to a reputable dealer.
- Clearly mark the path of the power cord to avoid tripping and/or damage by yard equipment such as lawn mowers, etc.
- Do not leave the blower unattended.
- Do not allow blower to be used or played with by children.
- Do not cover the air intakes when the blower is being used and do not insert small objects into any part of the blower.
- **WARNING** - Electrocution Hazard - DO NOT USE EXTENSION CORDS WITH THIS PRODUCT.
- Disconnect the blower from the power source and Water Slide when moving the slide.
- **WARNING** - To reduce the risk of fire or electric shock, do not use this blower with any solid - state speed control device.
- The blower should be securely staked to the ground before use.

Inflating the Water Park

4

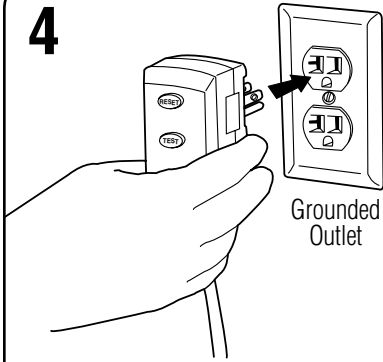

Test the Blower AC Adaptor:

- Plug GFCI into receptacle.
- Press reset button.
- Press test button.
- Press reset button to use product.

Do not use product if the test button fails to disable the blower.



WARNING:

If the blower remains ON when the "test" button is pushed, the unit is NOT working properly. DO NOT USE THE UNIT. Take the unit to a certified electrician immediately.

5

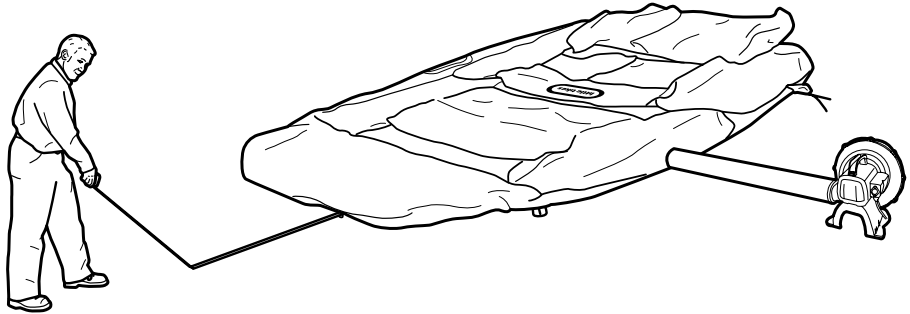
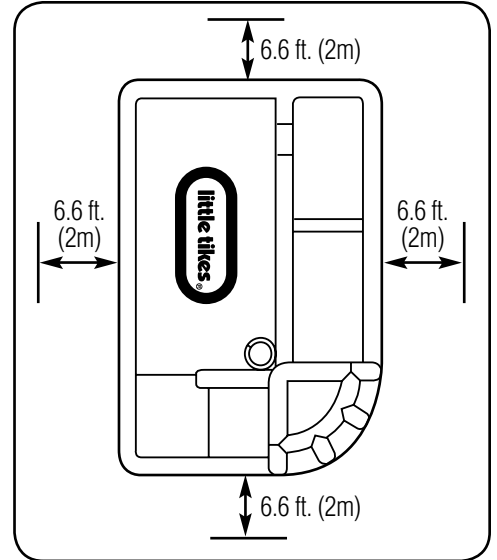
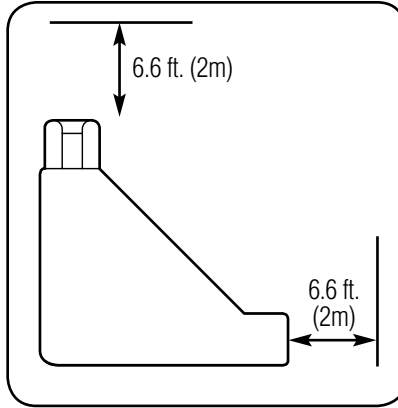

Re-measure minimum clearance zone prior to inflation.

6

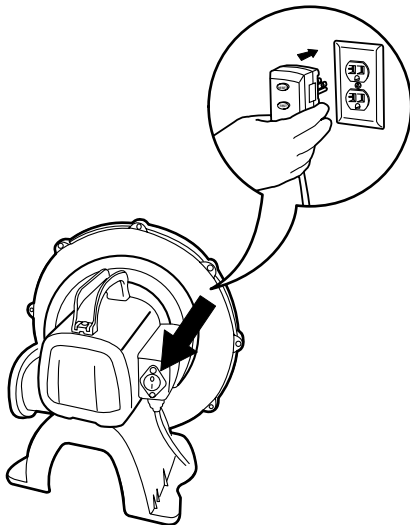

Switch power on. If blower does not operate when switched on, press reset button on GFCI adaptor.

7

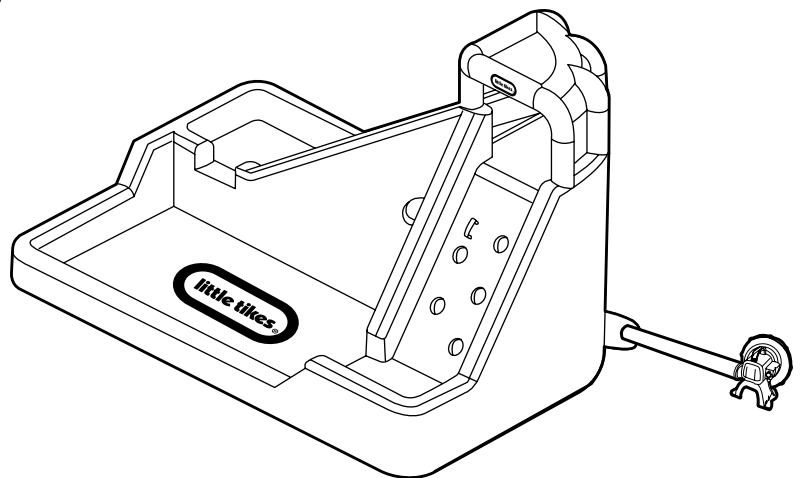

Water Park will inflate in 2 minutes. Blower should remain ON to continuously inflate the Water Park during use. Air flow through seams is normal (do not try to repair or seal seams).

Water Park Spray Assembly, Part

1

The Hose Assembly will attach to the Water Park as shown. Connect the Tubing Assembly to the hook and loop closures down the side of the slide.

Attach a garden hose to the end of the Tubing Assembly behind the slide.

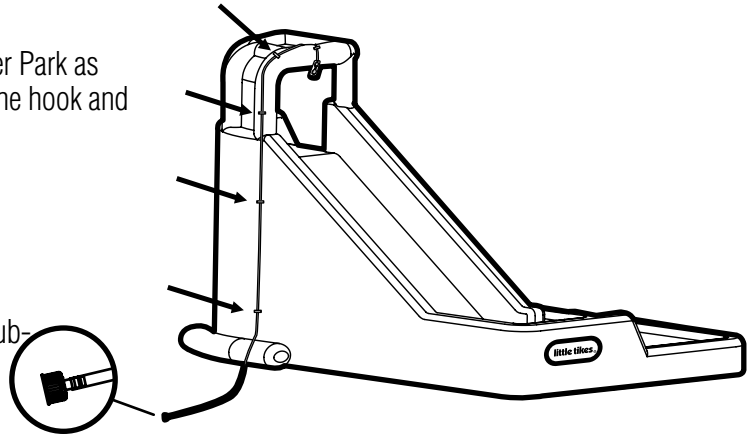

2

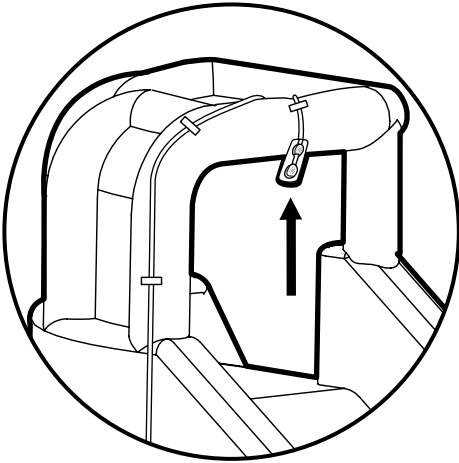

Connect the Double - Outlet Sprayer to the top of the red arch with the hook and loop fastener tape.

3

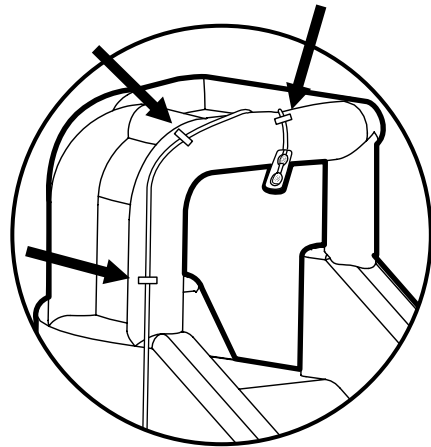

Attach the hose over the top and down the side of the red arch with the hook and loop fastener tape on the arch. Make sure that the Tubing Assembly is securely attached to the Water Park, with loop enclosures.

4

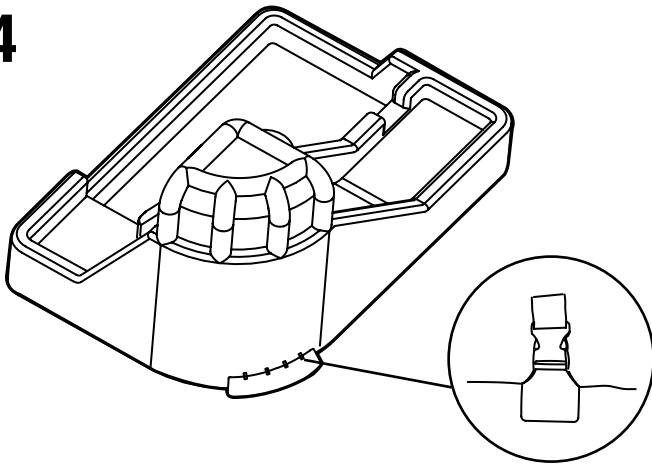

Once the Water Park is inflated, attach the Water Anchor Bag to the plastic connectors at the base of the Water Park.

5

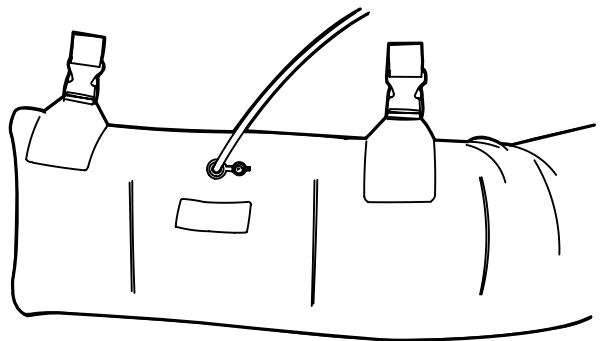

Once attached, fill the Anchor Bag with water until it is completely full.

NOTE: The Water Anchor bag needs to be attached to the Water Park whether or not the Water Sprayer is used. The Water Anchor Bag prevents the Water Park from toppling over when people climb on it.

Staking the Water Park

⚠ **CAUTION:** The Water Park and all its anchorage points should be checked before and during use. Reinflate or re-secure as appropriate. DO NOT let children play on the water park until it is fully inflated!

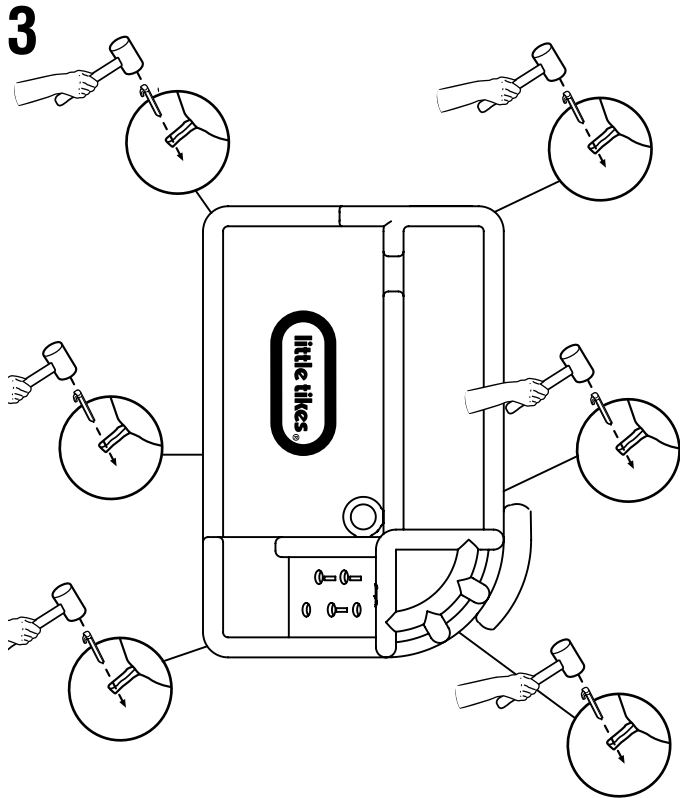

Secure the Water Park to the ground with the provided stakes. To prevent tripping, pull the stake loops all the way out, then drive stakes completely into the ground.

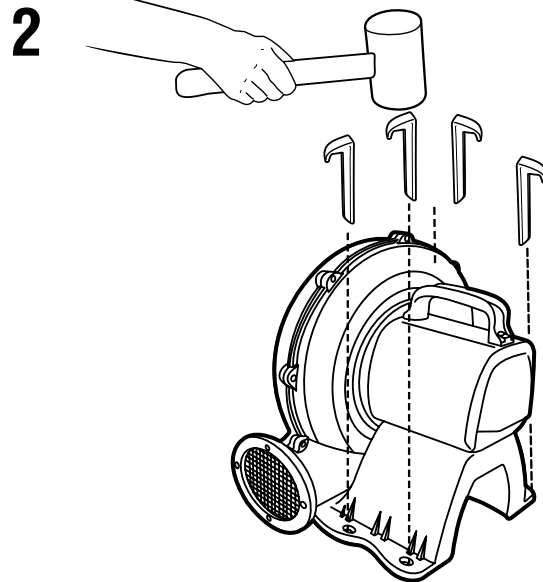

Secure the Blower to the ground with the provided stakes.

⚠ **WATER PARK CAUTIONS:**

- Drive ground stakes completely into the ground to avoid tripping hazard.
- Do not use the Water Slide until an Adult has assembled, staked down, and fully inflated it.
- Do not set up or inflate the Water Slide in windy and/or rainy conditions as wind gusts may cause the slide to become unstable and possibly be lifted from the ground.

Water Park Spray Assembly, Part

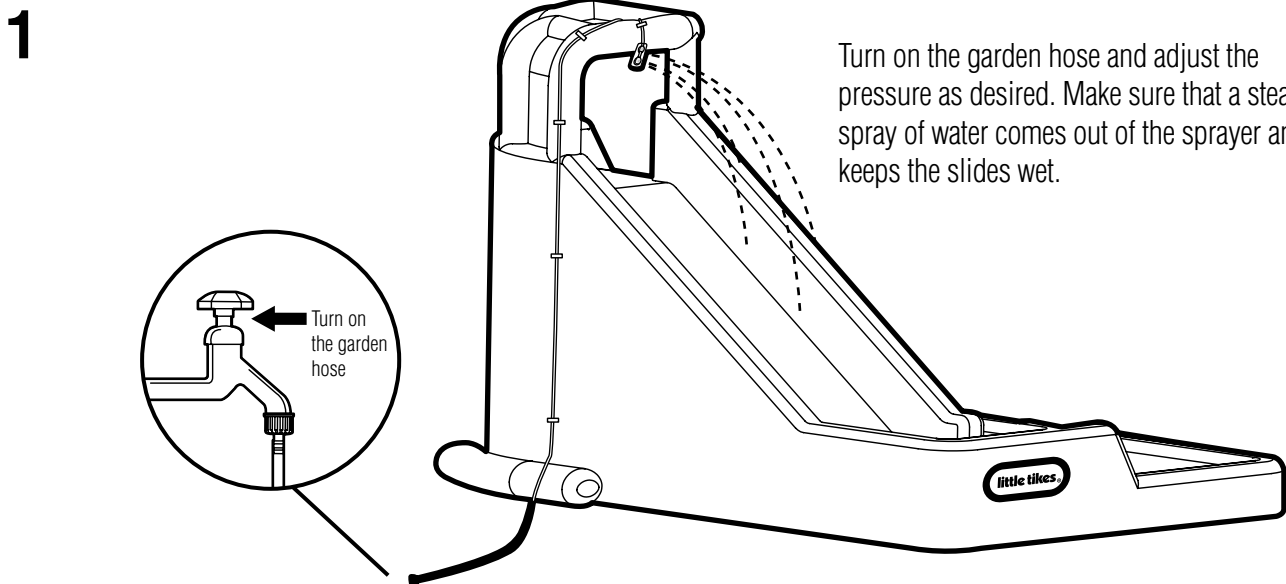

Turn on the garden hose and adjust the pressure as desired. Make sure that a steady spray of water comes out of the sprayer and keeps the slides wet.

Playing in the Water Park

NOTE: It is normal to see air bubbles rising from the pool floor and other wet areas of the Water Park.

SLIDING

1. Climb up the climbing wall to the top of the slide.
2. Sit on the top with your feet pointing down the slide.
3. Scoot forward and slide down into the splashdown area.
4. DO NOT slide down on your stomach or head first.
5. Do not face the sun when sliding.

⚠ CAUTION:

- Children can drown in a very small amount of water. Empty the pool when not in use.
- To avoid the risk of injury, ALWAYS slide down the slide with feet first. NEVER slide down on your stomach or head first.
- Only one child should be on the climbing wall or the slide at a time.
- Total weight of children must not exceed 300 lbs (max. individual weight=110 lbs) on the inflated surface.
- NEVER slide down the slide until the splashdown area is clear.
- NEVER slide or jump down the Climbing Wall.

Water Signs in Water Park

IMPORTANT:

To avoid serious injury and death, heed all warning signs that are printed on the Water Park. These signs are shown below:

! DANGER

NO DIVING OR JUMPING SHALLOW WATER

DIVING MAY RESULT IN PERMANENT INJURY OR DEATH



• CHILDREN MUST BE
ACCOMPANIED BY AN ADULT.

• NO RUNNING, JUMPING,
OR HORSEPLAY IN OR AROUND POOL.

• NO GLASS IN POOL AREA.



TO AVOID SERIOUS INJURY ALL POOL USERS MUST KNOW AND FOLLOW THESE SAFETY RULES.

WARNING:

NEVER JUMP OR DIVE FROM ANY PART OF THE WATER PARK!



**DO NOT
GO DOWN
THE CHUTE
BACKWARDS**



**NO DIVING,
BACKFLIPS OR
SOMERSAULTS**

WARNING:

ONLY SLIDE DOWN THE WATER SLIDE IN A SITTING POSITION WITH FEET IN FRONT OF YOU.



**NO
OUTDOOR
FOOTWEAR**

WARNING:

DO NOT USE OUTDOOR FOOTWEAR ON ANY PART OF THE WATER PARK AS IT MAY BECOME DAMAGED.

DANGER



SLIPPERY

DANGER



TRIP HAZARD

WARNING:

BE CAREFUL! SOME OF THE WATER PARK SURFACES ARE SLIPPERY AND MAY PRESENT A TRIPPING HAZARD.

⚠ CAUTION



CHILDREN CAN DROWN IN VERY SMALL AMOUNT OF WATER. EMPTY THE POOL WHEN NOT IN USE. DO NOT LEAVE CHILDREN UNATTENDED AT ANY TIME.

WARNING:

CHILDREN CAN DROWN IN VERY SMALL AMOUNT OF WATER. EMPTY THE POOL WHEN NOT IN USE. DO NOT LEAVE CHILDREN UNATTENDED AT ANY TIME.

Draining, Deflation & Storage

IMPORTANT - Inflatable Water Park MUST be drained of all water and be COMPLETELY DRY before storage in order to avoid mold and mildew. DO NOT fold and store Water Park if any moisture remains.

IMPORTANT - All children MUST EXIT the Water Park before deflation or draining water.

IMPORTANT - For best results, 2-4 people should drain and move the Water Park.

1

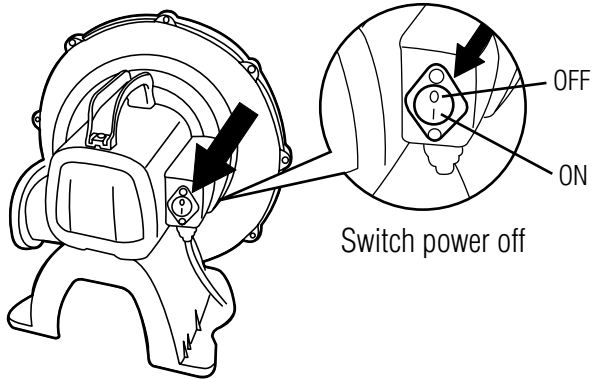

Turn off the blower motor and unplug it from the outlet..

2

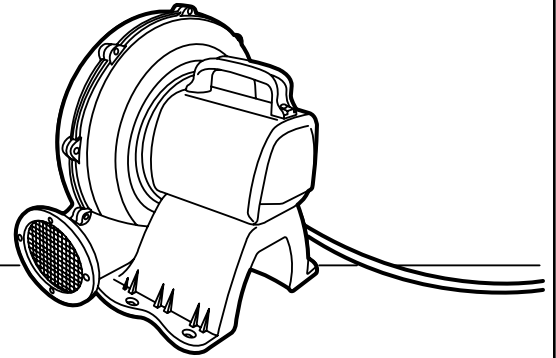

Move the blower to dry ground if it appears that it will get wet from draining water.

3

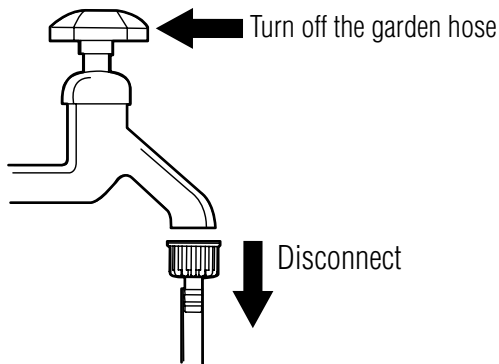

Turn off the garden hose and disconnect it from the Clear Plastic Tubing.

4

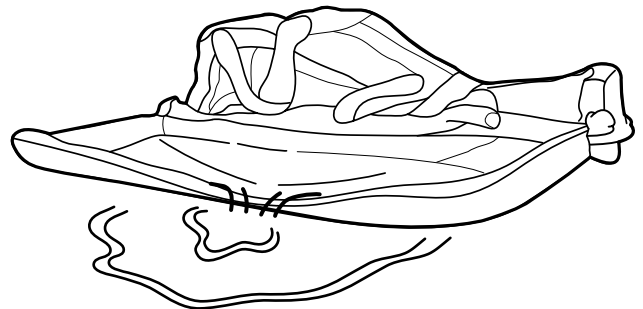

As the Water Park deflates, water will find the lowest point and drain from the collapsing pool walls.

5



Once most of the water has drained, with help from a friend (or friends), lift the bottom of the pool on one side to let the remaining water drain.

6

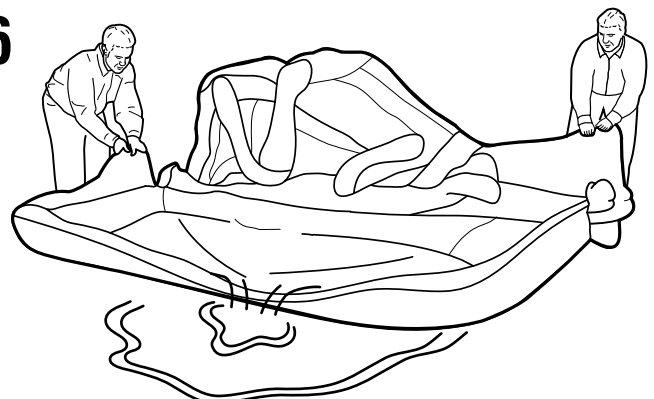

Repeat the process on the opposite side of the pool.

Draining, Deflation & Storage

7

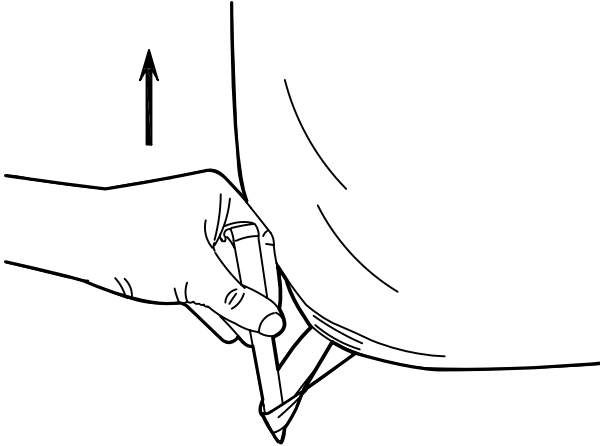

Remove stakes and drag the Water Park away from the drained water to a dry area.

8

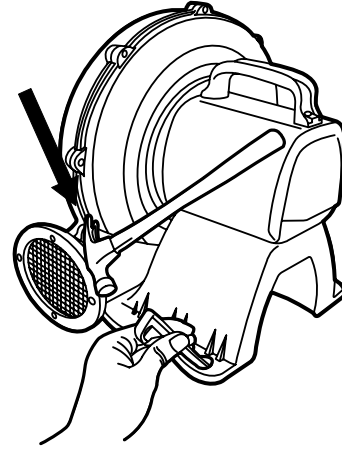

Re-stake the Water Park and blower, tie the Inflation tube to the blower, then reconnect and power up the blower.

9

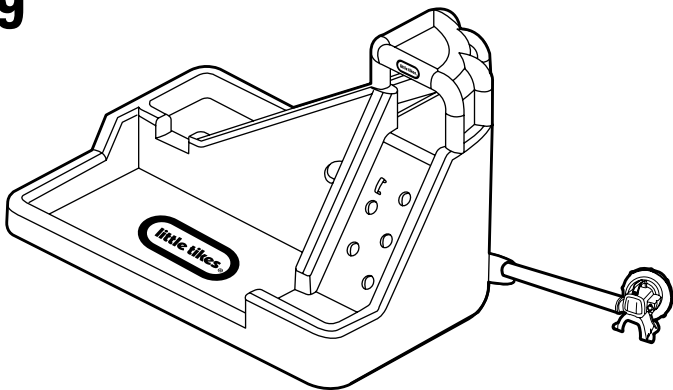

Leave the Water Park inflated until all remaining water has evaporated and the Water Park is dry. This may take 2 hours or more depending on weather conditions.

10

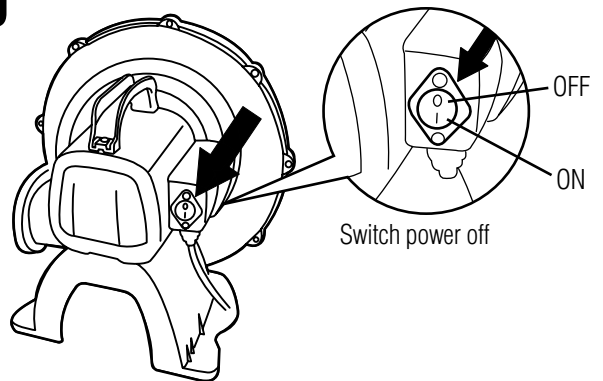

Once Water Park is completely dry, turn off blower motor and unplug it from outlet.

11

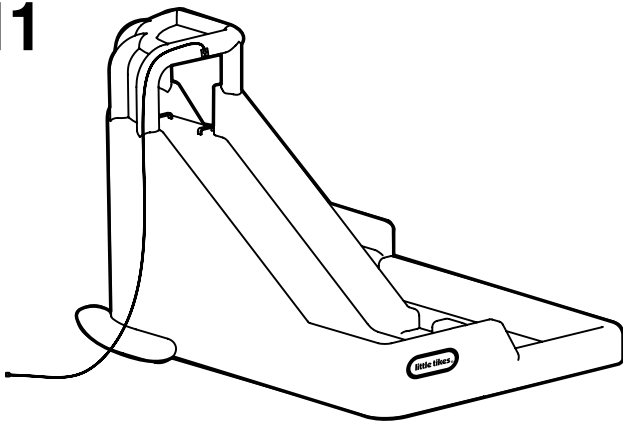

Remove and drain the Hose Assembly from the Water Park except for the red archway.

12

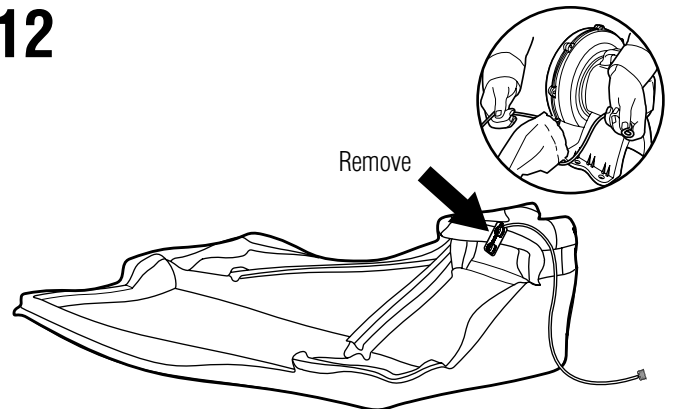

Untie the drawstring from the short Outlet Tube and allow the Water Park to fully deflate. Remove the Hose Assembly from the red arch and wrap it up with no kinks.

Draining, Deflation & Storage

13

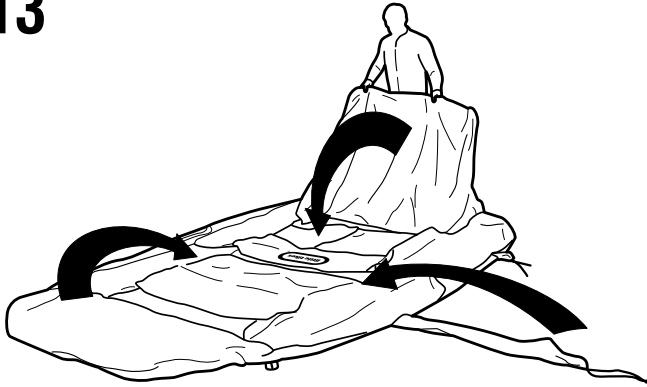

Fold all pieces of the Water Park (i.e. Slide, Air Inlet Tube, etc.) toward the center. NOTE: If bottom surface is still moist, allow it to air dry prior to folding.

14

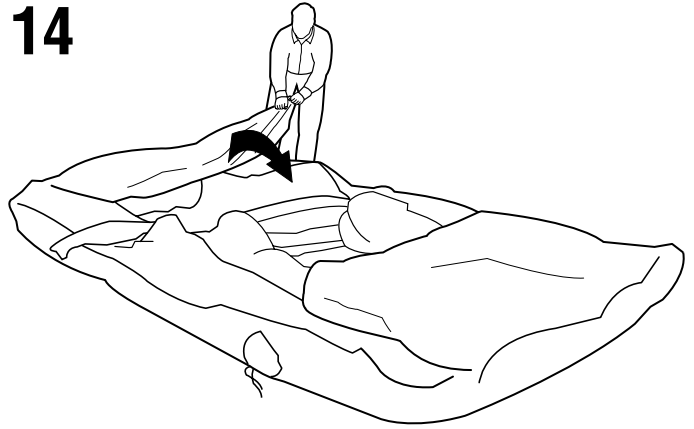

NOTE: Do not place the Water Spray Tubing inside the Water Park when rolling it up.

15

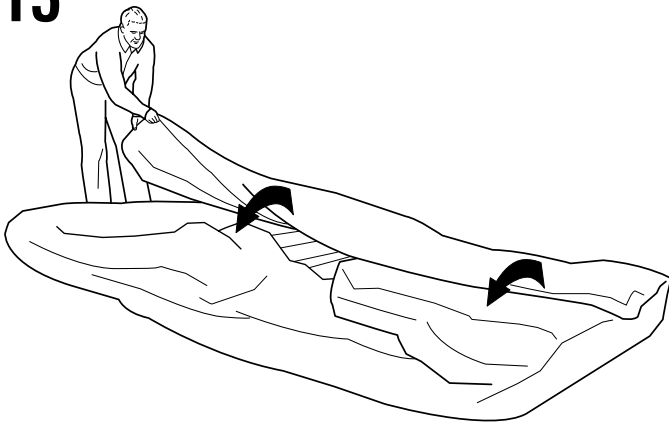

Fold the Water Park in half.

16

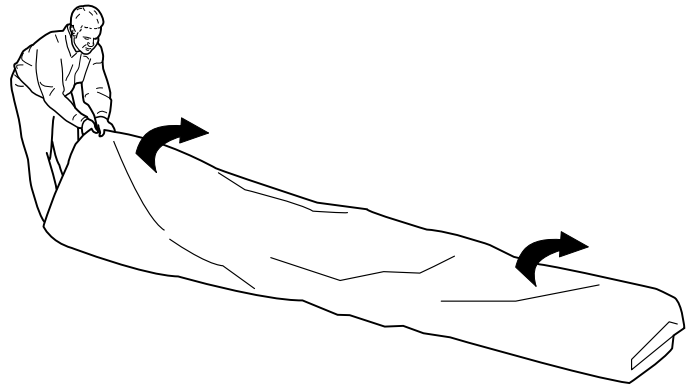

Then fold the Water Park in half again.

17

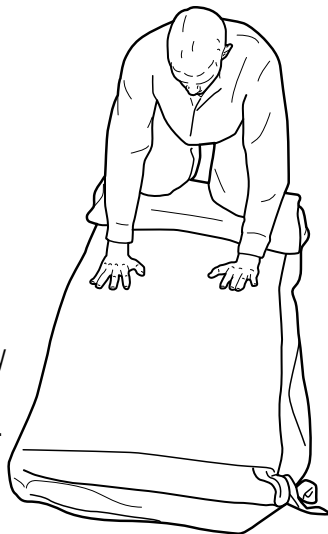

Roll up the Water Park tightly and compress the fabric to expel all of the remaining air.

18

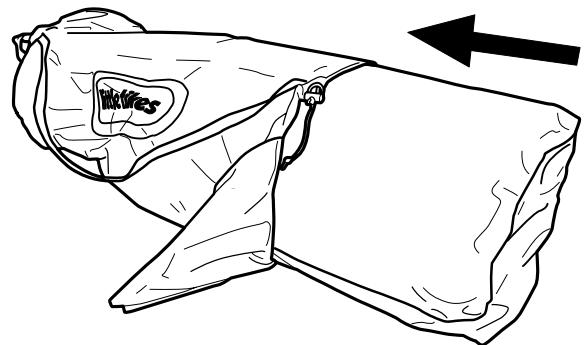

Store the rolled-up Water Park in the carrying bag.

Repair Kit Instructions

⚠ WARNING: NOT A TOY. ADULT USE ONLY.

19

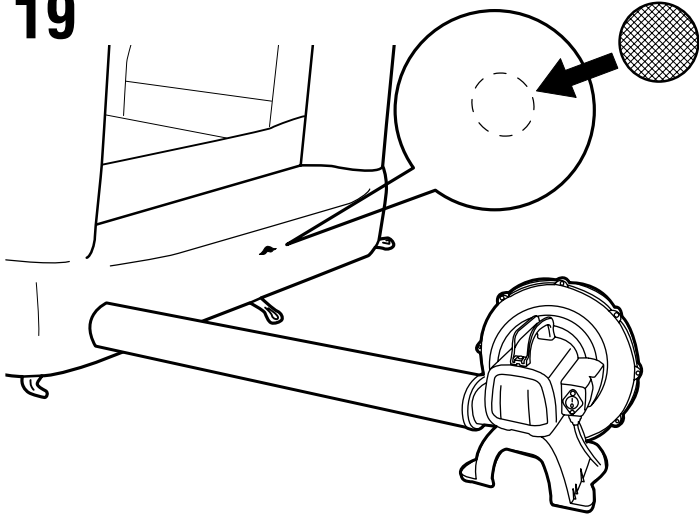

20 **correct**

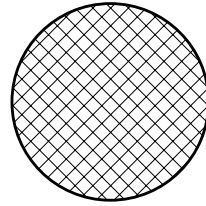

or

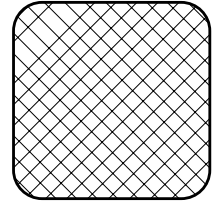

incorrect

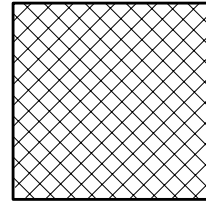

⚠ WARNING: Repair patches must be applied by an adult only. KEEP OUT OF REACH OF CHILDREN.

REPAIR PATCH INSTRUCTION

1. Deflate the item, clean the damaged area and allow it to dry thoroughly.
2. Cut a portion of the patch allowing approximately 1 1/2" of excess patch material on all sides of area to be repaired and round the corners. (See Fig. 19 & 20).
3. Remove the adhesive backing from the patch material, position the patch over the damaged area and smooth out any bubbles with a paper towel.
4. Allow to sit for 30 minutes before re-inflating.

Maintenance

- As an outdoor product, the inflatable is subject to wear and deterioration. Inspect for signs of fabric failure; weak or torn surfaces must be repaired promptly.
- Product should never be stored wet. Allow to dry before rolling up.
- Surface washable only.

Disposal

- Disassemble and dispose of the equipment in a safe manner so as not to produce hazardous conditions.
- Blower should be returned to a collection center capable of processing electrical/electronic waste.

Instructions for Blower Maintenance

- Blower must be unplugged before servicing.
- Product should be periodically examined for potentially unsafe conditions such as damaged cord, plug, housing, or parts, and in the event such damage is found, the product should not be used until properly repaired.
- The blower does not require any lubrication and has no user serviceable parts. Do not attempt to service the blower.
- Do not immerse the blower in water. To clean, wipe with a damp cloth.
- Regularly inspect the intake and output openings and keep free of dirt, leaves, etc.
- When not in use, store the blower indoors in a dry place.
- Store the blower upright on a stable surface.
- Loosely coil the cord and place it beside the blower.
- When in use, do not place the cord across traffic areas, water or damp area.
- The blower is a high volume blower, and is capable of moving large volumes of air very quickly. Place the blower in an area where it will not draw in dirt or leaves.



XIM607837-9/07

Please keep this manual as it contains important information.

TM & © The Little Tikes Company,
an MGA Entertainment Company.
Little Tikes™ and all related logos, names, characters,
distinctive likenesses and slogans, as well as the packaging
and images appearing thereon, are the exclusive property of
The Little Tikes Company.
Little Tikes Consumer Services
2180 Barlow Road
Hudson, Ohio 44236 USA
(800) 321-0183
Printed in China.

Visit us at www.littletikes.com