

⚠ WARNING! This toy produces flashes that may trigger epilepsy in sensitised individuals.

BATTERY SAFETY INFORMATION

- Use only size "AA" (LR6) alkaline batteries (3 required).
- Charging of rechargeable batteries should only be done under adult supervision.
- Remove rechargeable batteries from the product before recharging.
- Do not mix old and new batteries.
- Do not mix alkaline, standard (carbon-zinc), or rechargeable batteries.
- Be sure to insert the batteries correctly and follow the toy and battery manufacturer's instruction.
- Always remove exhausted or dead batteries from the product.
- Dispose of dead batteries properly: do not burn or bury them.
- Do not attempt to recharge non-rechargeable batteries.
- Avoid short-circuiting battery terminals.
- Remove batteries before placing the unit into storage for a prolonged period of time.

FCC COMPLIANCE

NOTE: This equipment has been tested and found to comply with the limits for a Class B digital device, pursuant to Part 15 of the FCC Rules. These limits are designed to provide reasonable protection against harmful interference in a residential installation. This equipment generates, uses and can radiate radio frequency energy and, if not installed and used in accordance with the instructions, may cause harmful interference to radio communications. However, there is no guarantee that interference will not occur in a particular installation. If this equipment does cause harmful interference to radio or television reception, which can be determined by turning the equipment off and on, the user is encouraged to try to correct the interference by one or more of the following measures:

- Reorient or relocate the receiving antenna.
- Increase the separation between the equipment and receiver.
- Connect the equipment into an outlet on a circuit different from that to which the receiver is connected.
- Consult the dealer or an experienced radio/TV technician for help.

This device complies with Part 15 of the FCC Rules. Operation is subject to the following two conditions: (1) This device may not cause harmful interference, and (2) this device must accept any interference received, including interference that may cause undesired operation.

Caution: Modifications not authorized by the manufacturer may void users authority to operate this device. CAN ICES-3 (B)/NMB-3(B).

LIMITED WARRANTY

The Little Tikes Company makes fun, high quality toys. We warrant to the original purchaser that this product is free of defects in materials or workmanship for one year * from the date of purchase (dated sales receipt is required for proof of purchase). At the sole election of The Little Tikes Company, the only remedies available under this warranty will be the replacement of the defective part or replacement of the product. This warranty is valid only if the product has been assembled and maintained per the instructions. This warranty does not cover abuse, accident, cosmetic issues such as fading or scratches from normal wear, or any other cause not arising from defects in material and workmanship. *The warranty period is three (3) months for daycare or commercial purchasers. U.S.A and Canada: For warranty service or replacement part information, please visit our website at www.littletikes.com, call 1-800-321-0183 or write to: Consumer Service, The Little Tikes Company, 2180 Barlow Road, Hudson OH 44236, U.S.A. Some replacement parts may be available for purchase after warranty expires—contact us for details. Outside U.S.A and Canada: Contact place of purchase for warranty service. This warranty gives you specific legal rights, and you may also have other rights, which vary from country/state to country/state. Some countries/states do not allow the exclusion or limitation of incidental or consequential damages, so the above limitation or exclusion may not apply to you.



'Let's care for the environment!'

The wheellie bin symbol indicates that the product must not be disposed of with other household waste. Please use designated collection points or recycling facilities when disposing of the item. Do not treat old batteries as household waste. Take them to a designated recycling facility.

Please keep this manual as it contains important information.

© The Little Tikes Company, an MGA Entertainment company. LITTLE TIKES® is a trademark of Little Tikes in the U.S. and other countries. All logos, names, characters, likenesses, images, slogans, and packaging appearance are the property of Little Tikes.

Printed in China
0321-0-E/INT



Little Tikes Consumer Service
2180 Barlow Road
Hudson, Ohio 44236 U.S.A.
1-800-321-0183

MGA Entertainment UK Ltd.
50 Presley Way, Crownhill, Milton
Keynes, MK8 0ES, Bucks, UK
support@LittleTikesStore.co.uk
Tel: +0 800 521 558

MGA Entertainment (Netherlands) B.V.
Baronie 68-70, 2404XG Alphen a/d Rijn
The Netherlands
Tel: +31 (0) 172.758038

Imported by MGA Entertainment Australia Pty Ltd
Suite 2.02, 32 Delhi Road
Macquarie Park NSW 2113
1300 059 676



3-in-1 Sports Zone™

AGES 12-36 MONTHS

ADULT SUPERVISION REQUIRED

ADULT ASSEMBLY AND BATTERY INSTALLATION REQUIRED

SKU: 643224P1

CONTENTS

- | | |
|---|----------------------|
| A. 1 Center Post (Vertical Supports A and B Attached) | G. 1 Soccer Net |
| B. 1 Basketball Board | H. 1 Basketball Hoop |
| C. 1 Base Support | I. 1 Bowling Ball |
| D. 1 Left Bowling Support | J. 1 Basketball |
| E. 1 Right Bowling Support | K. 1 Soccer Ball |
| F. 1 Soccer Support | |

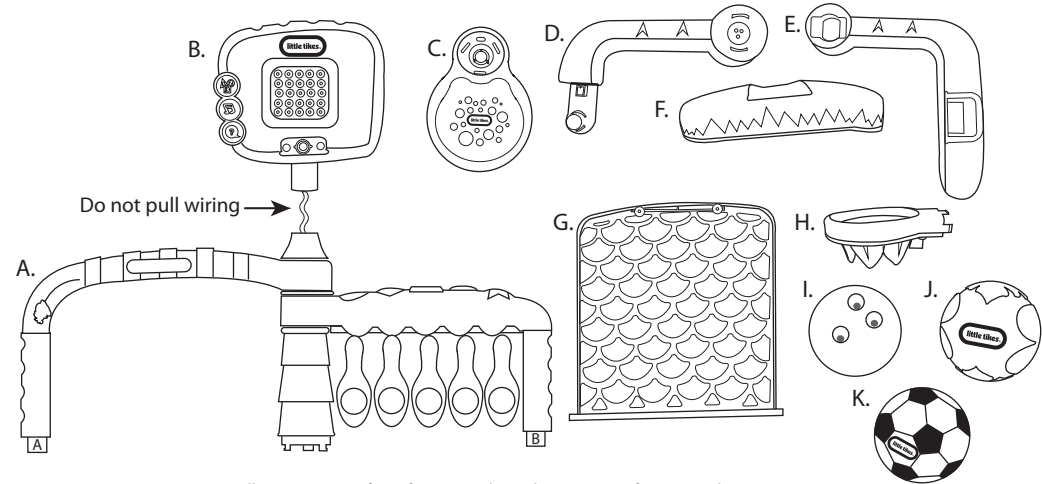

Illustrations are for reference only. Styles may vary from actual contents.

BATTERY INSTALLATION

Before beginning, an adult must install fresh alkaline batteries. Here's how:

1. Using a Phillips screwdriver (not included), remove the screw and battery compartment cover located on the back of the basketball board.
2. Install three (3) fresh 1.5V AA (LR6) alkaline batteries (not included) making sure the (+) and (-) ends face the proper direction as indicated inside the battery compartment.
3. Replace the compartment cover and tighten the screw.

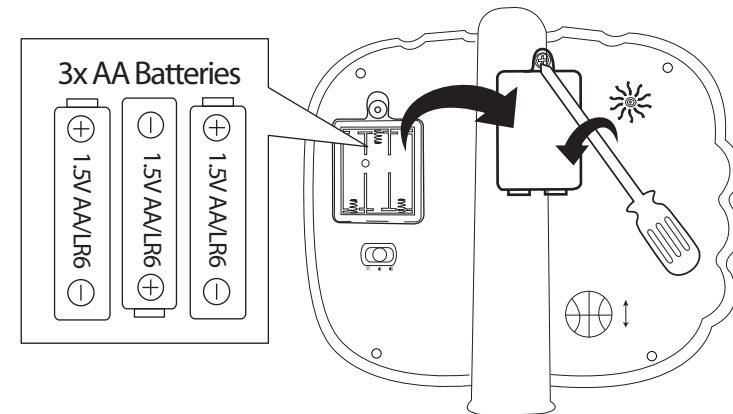

ASSEMBLY

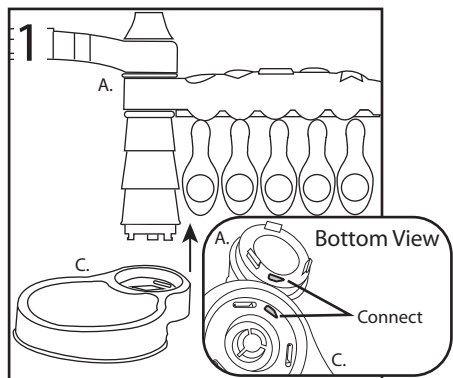

Add the base support (C) to the bottom of the center post (A). Connect the tabs (shown above) first and then attach the remaining tabs.

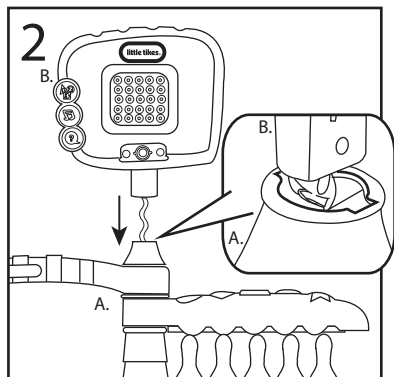

Slide the basketball board (B) into the center post (A). Make sure to insert the wiring into the center post.

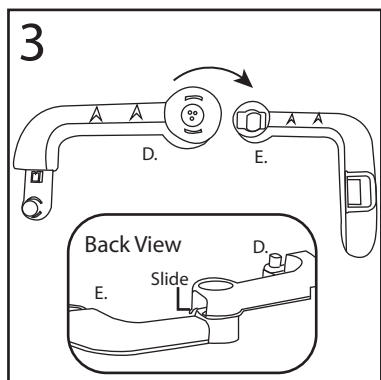

Slide the rounded end of the left bowling support (D) over the rounded end of the right bowling support (E).

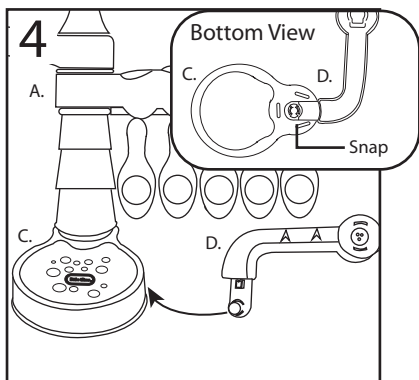

Snap the left bowling support (D) to the bottom of the base support (C).

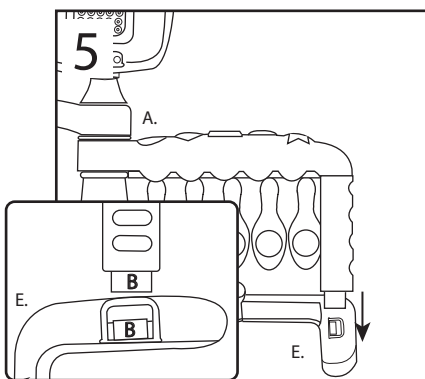

Connect the vertical support on the center post's (A) bowling arch to the right bowling support (E). The vertical support and right bowling support will be etched with a B.

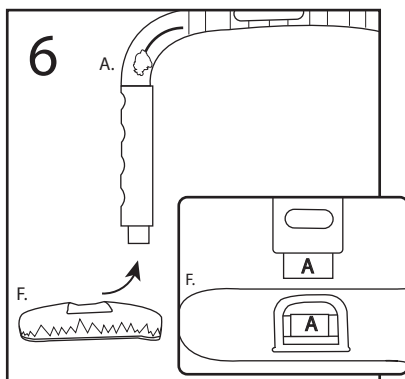

Connect the soccer support (F) to the bottom of the vertical support on the center post's (A) soccer arch. The vertical support and soccer support will be etched with an A.

GAMES

Press the play button to follow directions and play along. The screen on the basketball board will flash a question mark while saying, "Hey superstar, can you follow directions?" It will then prompt an action to play an activity. It will give a response whether the action is correct or incorrect.

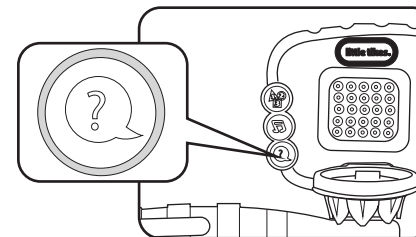

ACTIONS

- "Let's see you kick a goal!"
- "Try to knock all the pins!"
- "Shoot three baskets in a row!"
- "Can you press the shapes down?"

CORRECT

- "Goooooaaaaa!"
- "You're king of the jungle."
- "Woo hoo!"
- "You hit all five."
- "Let's play some more!"
- "You did it."

INCORRECT

- "Try that again!"
- "Good try."
- "Almost!"
- "Now try and hit the other pins!"

SLEEP MODE

After 8 seconds of no action, it will play sounds. 8 seconds later it will say a phrase, and if there is still no activity 8 seconds later, it will go to sleep.

PHRASES

- "Let's play and learn numbers" or "colors."
- "Let's see you kick a ball."
- "Can you kick, dunk or roll a ball?"
- "Try to knock all the pins!"
- "Can you roll the ball?"
- "Choose a mode to begin!"
- "Can you press the shapes down?"
- "See ya later superstar."
- "Can you press a button?"

MORE PHRASES

- "Hey jungle friend, get ready to play some sports."
- "Can you slam dunk?"
- "You're doing great."
- "You rock treetops."
- "You scored a goal."
- "Five in a row."

BOWLING PHRASES

- "That's a strike."
- "You hit all five pins: red, orange, yellow, green and blue."
- "Great job."
- "You hit two pins: green and blue" or "orange and red."
- "Great job."
- "Now try and hit the other pins."
- "Cool!"
- "You hit one pin: blue" or "red."
- "Yippee!"
- "Wow!"
- "Well done."
- "That was coconuts."
- "Now, press all the shapes down to play again!"

MOVE

Press the music button to hear tunes and animals sounds. The screen on the basketball board will randomly flash music notes while playing sounds and saying, "It's time to move and groove."

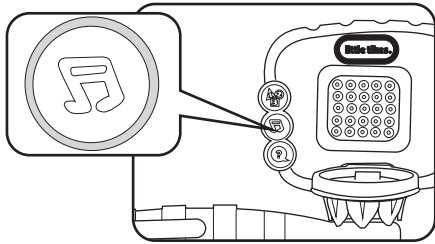

SOCCER & BASKETBALL

Make a goal or basket to hear all the different tunes and sayings.

SOCCER & BASKETBALL PHRASES

- "Goooooaaaaal!"
- "Woo Hoo!"
- "Kapow!"
- "Let's play some more!"
- "Great job!"
- "That was slamtastic."

BOWLING

Hit the pins to hear all the different tunes, sayings and animal sounds. When all the pins have been knocked back, it will say, "Now, press all the shapes down to play again." When pressing down the shapes, it will make different sounds.

ANIMAL SOUNDS & PHRASES

- Squawk, squawk!
- Elephant's trunk.
- Roar.
- Ooh, ooh, aah, aah.
- "Now try and hit the other pins."
- "That was slamtastic."
- "That was coconuts."
- "Let's play some more!"
- "Circle!"
- "Heart!"
- "Triangle!"
- "Square!"
- "Star!"

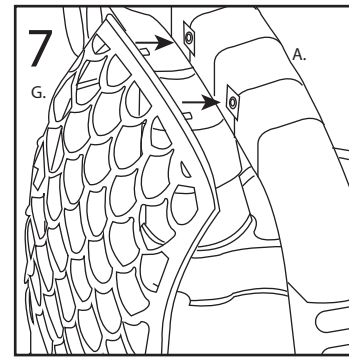

Clip the soccer net (G) to the back of the center post's (A) soccer arch.

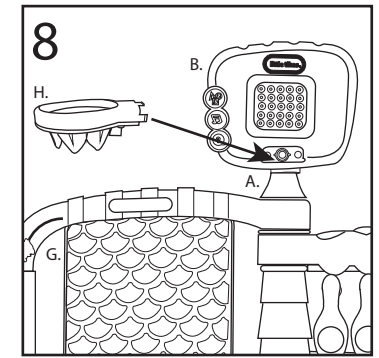

Install the basketball hoop (H) to the basketball board (B).

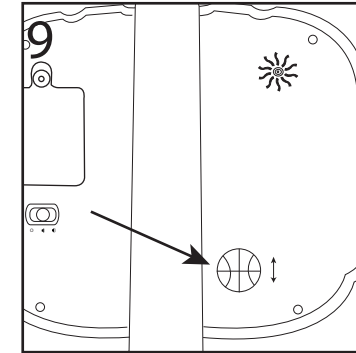

Adjust the basketball board to the preferred height by pressing on the basketball button on the back and sliding it up or down.

STORING

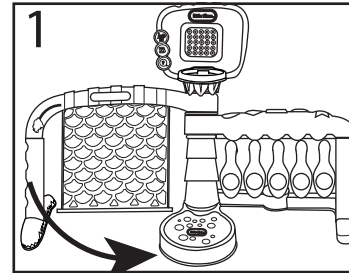

Slide the soccer side to the center and directly under the basketball hoop.

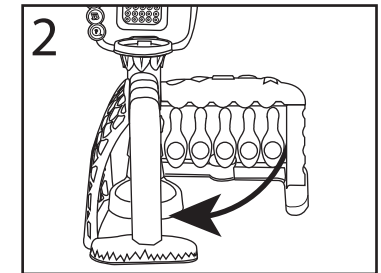

Slide the bowling side under the soccer arch.

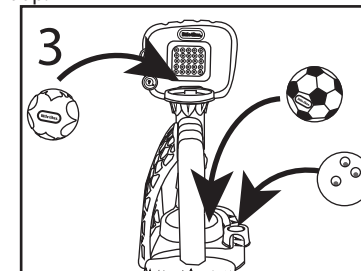

Store the bowling ball, basketball and soccer ball.

QUICK START

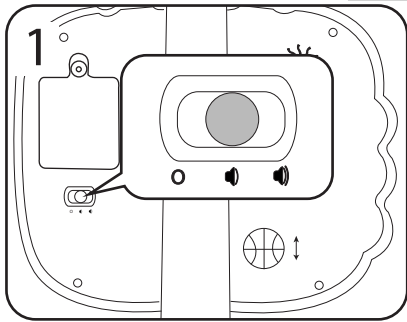

Turn the 3-in-1 Sports Zone™ on by choosing a volume preference.

- O = Off
- = Low Volume
- = High Volume

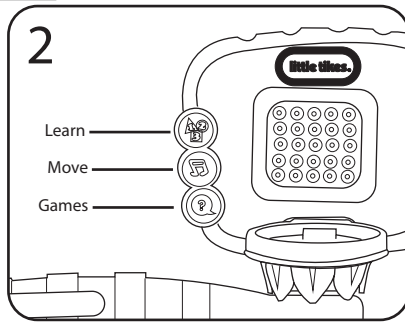

Then, choose a game mode.

- Learn:** Learn numbers, shapes and colors.
- Move:** Listen to tunes and animals sounds.
- Games:** Follow directions and play along.

LEARN

Press the learning button to learn numbers, shapes and colors. The screen on the basketball board will begin to flash numbers.

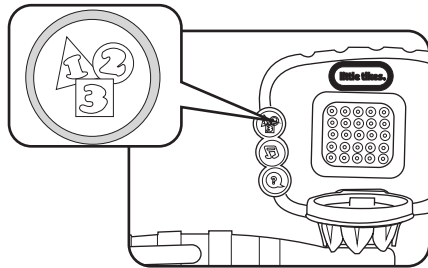

SOCCER

When playing soccer in learning mode, make five goals to learn numbers 1-5 with different sounds and sayings.

- Kick the ball to make your first goal.
- The screen on the basketball board will display the number one and say, "One, that was fun." Continue to make goals to watch the screen count all the way to five and hear all the different phrases.

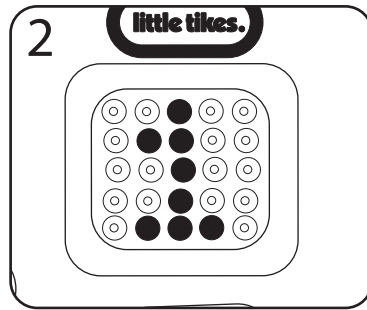
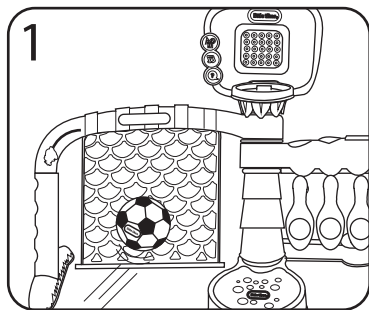

SOCCER PHRASES

- "Woo hoo, that's two!"
- "Three, whoopee!"
- "Good score on number four."
- "Looking alive, that's number five."
- "Great job."
- "Let's play some more."

BASKETBALL

When playing basketball in learning mode, make 10 baskets to learn numbers 1-10 with different sounds and sayings.

- Shoot your first basket.
- The basketball board will make a swish sound, say and display the number one. Continue shooting baskets to count all the way to 10 and hear all the different phrases.

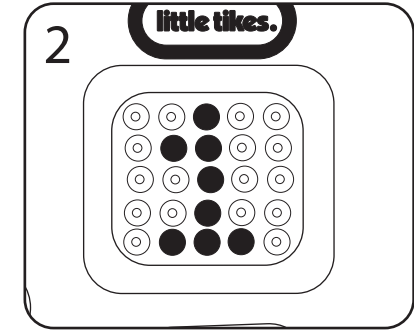
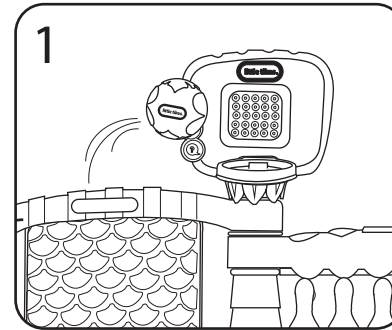

BASKETBALL PHRASES

- "Wow!"
- "You're not monkeying around."
- "Keep going!"
- "Ten in a row."
- "That's a perfect score."
- "That's bananas."
- "That was slamtastic."
- "Let's play some more!"
- "One, Two, Three, Four, Five, Six, Seven, Eight, Nine, Ten."

BOWLING

When bowling in learning mode, hit the pins to learn shapes and colors. Once you hit a pin, the pin will flip back and the shape on top of the arch will pop up. The basketball board will display how many pins were hit and their colors. When resetting the pins, it will say the name of the shape and display it on the screen.

- Knock the yellow pin for a strike.
- Knock the green pin to knock two pins back: the green and blue.
- Knock the orange pin to knock two pins back: the orange and red.
- Knocking the blue or red pin will only knock back one.
- To reset, press down the shapes on top of the arch.

